

Datasheet

AvTrak 6 OEM Transceiver

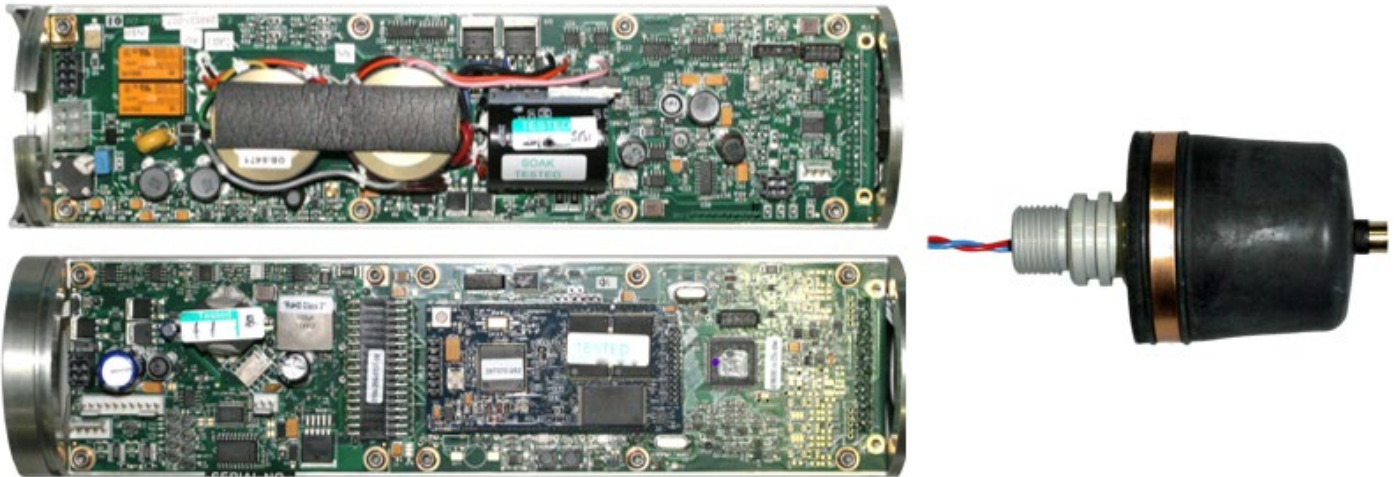

The AvTrak 6 OEM transceiver is specially designed for underwater vehicles. The lightweight rechargeable transceiver design allows for easy integration into autonomous vehicles and provides all the features supported by the standard AvTrak 6 transceiver.

The integrated Li-ion rechargeable battery provides up to 30 days emergency standby life, allowing sufficient time to relocate and recover a lost vehicle.

The AvTrak 6 transceiver operates in the Medium Frequency (MF) band so it is compatible with Sonardyne's Ranger 2 and Mini-Ranger 2 6G® Wideband® Ultra-Short Baseline (USBL) systems.

The AvTrak 6 supports the standard 6G command language (thereby simplifying development across the 6G instrument range) and Sonardyne's Messaging Service (SMS) telemetry, which provides an integrated navigation and data link vehicle solution in a single instrument.

As part of a 6G USBL system, the Avtrak 6 supports high update rate position information, where the prior position is communicated to the vehicle on each navigation cycle. This considerably reduces the position aiding latency.

The OEM chassis can be customised to provide mounting points for specific vehicle internals and is supplied with a threaded boss mount MF omni-directional transducer for integration into a vehicle.

Key features

- Small size for fitting in small AUVs or ROVs
- Standard 6G Command Language to allow easy migration from other 6G transceivers or OEM solutions
- Operating range typically up to 3,000 m
- RS232 serial interface
- MF operation
- Standard, oil filled, omni-directional transducer
- Compatible with Sonardyne Ranger 2 and Mini-Ranger 2 USBL systems
- Integrated navigation and telemetry solution
- Optional pressure sensor input for depth aiding
- >300 independent acoustic addresses
- Emergency recovery transponder
- High update rate, low latency telemetry position aiding capability

Specifications

AvTrak 6 OEM Transceiver

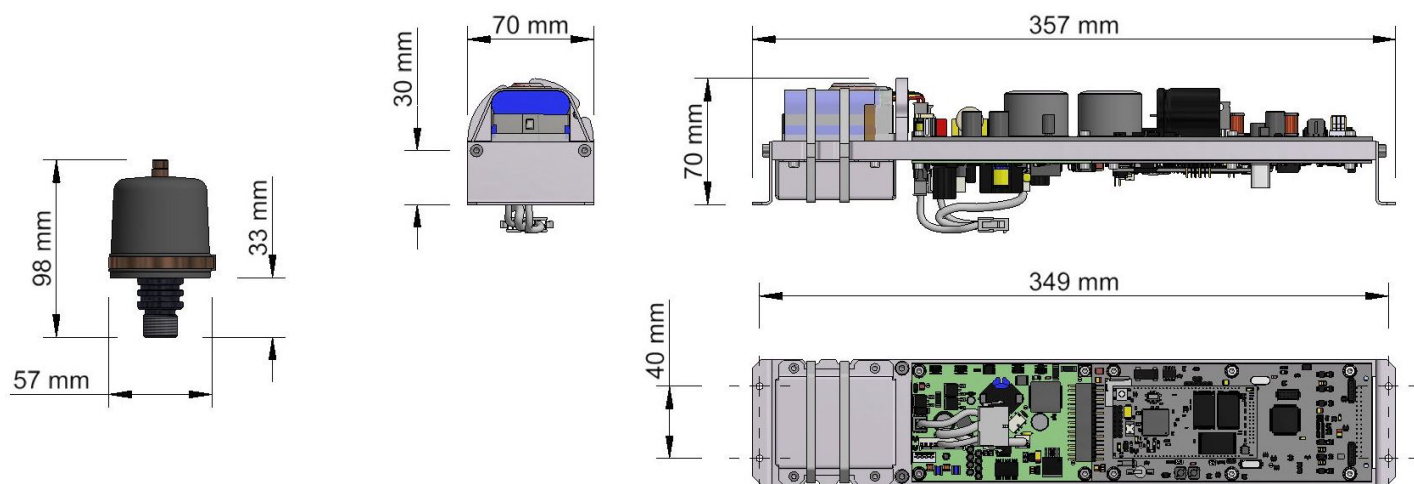

Feature		Type 8220 OEM
Operating range		3,000 m
Frequency band		MF (20–34 kHz)
Transducer beam shape		Omni-directional $\pm 130^\circ$
Source level (re 1 μPa @ 1 m)		187 dB
Communication interface		Serial RS232
Pressure sensor (optional)		100 or 400 bar ($\pm 0.5\%$ FS)
Power supply ¹		24/48 V dc ($\pm 10\%$) 650 mW to 6 W (depending on battery charge state) <50 W peak power when transmitting telemetry
Battery life	Quiescent listening	>30 days
	1 second ping rate	>1 day
External connections ²	PL2-5 RS232 RX (PC TX) PL2-6 RS232 TX (PC RX)	PL2-1 Comms 0 V PL1-1 +V external dc voltage 24/48 V ($\pm 10\%$) PL1-3 Power 0 V (isolated from comms 0 V)
Transducer wire length ³		150 mm (6")
Operating temperature		-5 to 40°C
Storage temperature		-20 to 55°C
Chassis dimensions (length x height x depth)	With mounting bracket	357 x 70 x 70 mm
	Without mounting brackets	335 x 69 x 70 mm
Weight in air	Chassis (including battery)	1.34 kg
	Transducer	300 g

¹ Any noise on the external dc supply will have an effect on the acoustic performance of the instrument.

² Extra care is required when connecting the OEM transceiver to external equipment as minimal protection is provided.

³ It is possible to increase the transducer wire length if required; contact Sonardyne for more information.