

Datasheet

Modem 6 OEM Nano

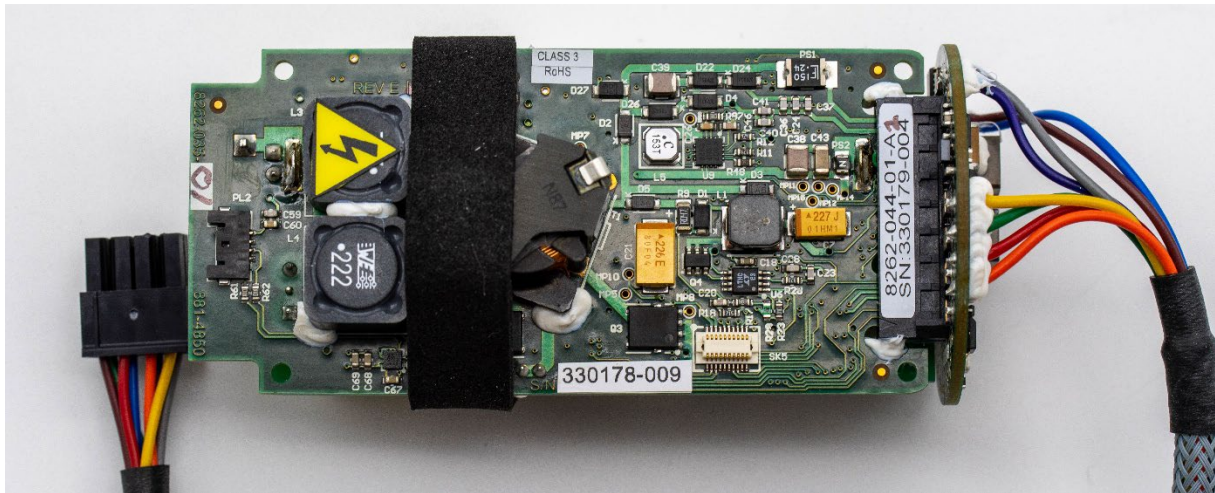

The Modem 6 is based on existing 6G® equipment and provides a reliable and cost-effective method of wirelessly transferring underwater sensor data in real-time.

The Modem 6 OEM Nano is the smallest OEM Modem (with a battery pack) on the market. Easy-to-mount and suitable for transmission of data from a wide range of sensors including current and custom instrumentation.

The Modem 6 OEM Nano is available in Medium Frequency (MF) with an omni-directional 3000 m transducer for excellent horizontal and shallow water communication.

Modem 6 is a flexible range of instruments, supporting specific communication settings for a variety of link types such as low latency data, fire and forget, acknowledged and large data uploads. A 512 kB modem buffer stores data when a modem link is not active.

All Modem 6 products utilise Sonardyne Wideband® signal processing and standard 6G control language. They can be programmed using the supplied software and a serial link or any third-party terminal software.

This technology is field proven and provides unprecedented levels of robustness and flexibility in challenging acoustic environments.

Data transfer rates range from 9,000 bps down to 200 bps depending on the environment.

Advanced communication protocols and intelligent data packet stitching ensure latency is minimised and data is delivered error free.

Designed to be integrated into persistent seabed sensors and subsea platforms Modem 6 OEM Nano brings the benefits of Sonardyne's established Modem range to a new integrator market.

Key features

- Omni-directional
- Sonardyne Wideband telemetry provides up to 9,000 bps actual acoustic data rate
- Compatible with all Modem 6 instruments
- Full two-way Sonardyne Wideband 2 interrogation and reply – mitigates interference and multi-path issues
- Acknowledged and fire and forget modes
- More than 500 unique Sonardyne addresses
- Robust performance in noisy and reverberant environments
- Internal back-up battery with external trickle charge
- Scalable solution with AvTrak 6 and Sonardyne Modem 6 range
- Simulation software available

Specifications

Modem 6 OEM Nano

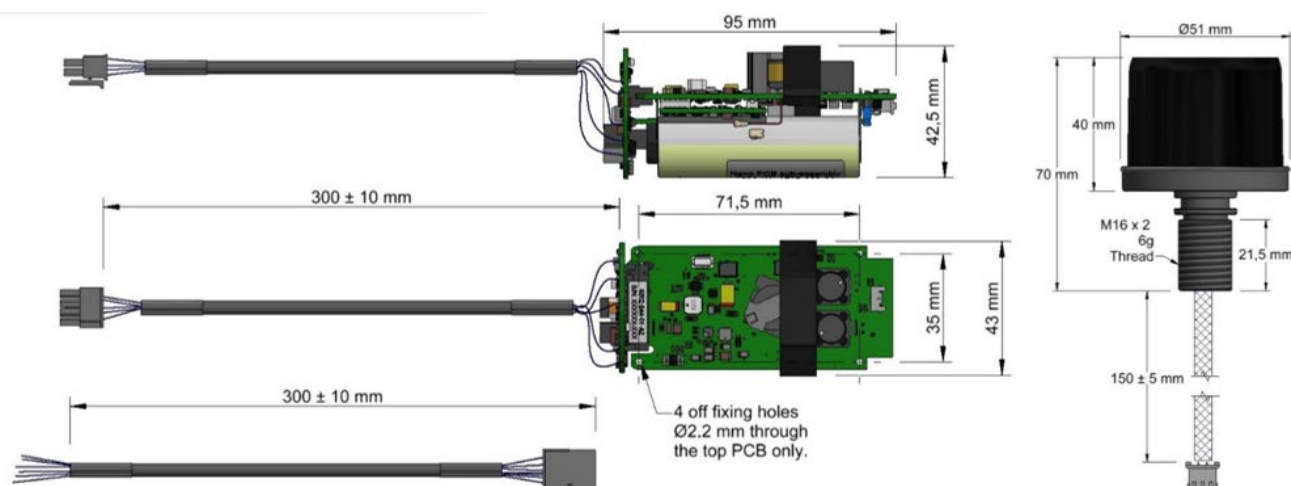

Feature		Type 8262 Modem 6 OEM Nano
Operating range		2,000 m
Transducer depth rating		3,000 m
Operating frequency		MF (20–34 kHz)
Transducer beam shape		Omni-directional ±130°
Source level (re 1 µPa @ 1 m)		175 dB
Communications interface		RS232 (2,400–115,200 baud), 3V3 TTL
Power supply		12–28 V dc
Bit rate		200 – 9,000 bits/sec
Bit error rate		>10 ⁻¹⁰
Buffer size		512 kB
Power supply ¹		12–28 V dc
Power consumption	Wideband listening (battery)	5 mW
	Wideband listening (external power) ²	20 mW (including trickle charge)
	Battery charging	60 mW to 2.5 W (depending on battery charge state)
	Peak (during transmission)	<30 W SMS, <20 W Modem
Battery Life (listening)		>90 Days
Battery charge time		12 hours
Tilt sensor		±90°
External connections		Molex Microfit
Transducer wire length ³		150 mm (6")
Operating temperature ⁴		-10 to 45°C
Storage temperature ⁵		-20 to 55°C
Dimensions	Transducer (length x diameter)	72 x 49 mm
	PCB board assembly (length x width x height)	95 x 43 x 42.5 mm
	Hole centres (M2 clearance – length x width)	71.5 x 35 mm
Weights	PCB in air	138g PCB + 12g cable
	Transducer in air/water (estimated)	200/150 g

¹ Noise on the external dc supply may have an effect on the acoustic performance of the instrument.

² Includes top-up charging of the li-ion battery, which could be disabled, or managed intelligently for better efficiency.

³ It is possible to increase the transducer wire length if required; contact Sonardyne for more information.

⁴ The battery will not charge above 45°C or below 0°C.

⁵ To maximise battery life, the instrument should not be stored above 30°C.