

Datasheet

Fetch (long-life) – wireless autonomous sensor logging node



Fetch is a long-life subsea sensor logging node that enables data to be wirelessly extracted via its integrated high-speed acoustic modem.

Fetch can be configured with an array of different sensors dependent on the monitoring application. Sensor options include low drift, high accuracy pressure, temperature and sound velocity as well as inclination. Other sensors can be integrated internally or externally as required. Fetch can also autonomously collect and log acoustic baseline ranges to other units.

Bluetooth and serial links are available for testing and configuration before deployment, as well as an acoustic modem, which is also used to recover the data to the surface.

The 9,000 bps modem transfer rate enables data to be extracted in minimal vessel time reducing operational costs.

The ultra-low power platform only powers up sensors when required and logs and timestamps the data to an internal SD memory card.

High-capacity primary lithium battery packs enable deployments of many years, dependent on sensor selection and sampling rate. Fetch can therefore either be left on the seabed or configured with optional release and buoyancy for recovery. Several stand designs are available to suit specific applications.

Fetch is compatible with Sonardyne's Ultra-Short BaseLine (USBL) positioning systems for positioning during deployment/recovery.

Key features

- Autonomous sensor logging with acoustic telemetry of data
- Low data recovery costs
- Long-life – Typically 12 years battery life with corrosion resistant titanium components
- Integrated modem with data rates ranging from 100 to 9,000 bps in multiple frequency bands
- Easy to set-up with configuration and sampling period programmable via telemetry link
- Sonardyne Wideband[®]1, Wideband 2, Wideband 2+ and HPR 400 USBL mode compatible
- Low-cost free-fall deployment option

Specifications

Fetch (long-life) – wireless autonomous sensor logging node

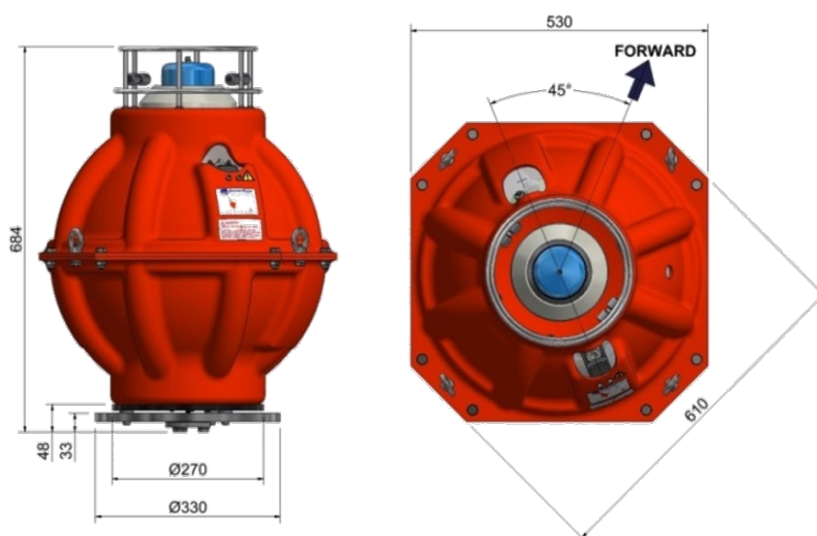

Feature		Type 8306
Depth rating		3,000 or 6,000 m
Operating frequency		MF (20–34 kHz) or LMF (14–19 kHz)
Transducer beam shape		Omni-directional $\pm 110^\circ$ or directional $\pm 40^\circ$
Transmit source level (dB re 1 μPa @ 1 m)		190–202 dB (4 levels)
Receive sensitivity (dB re 1 μPa)		90–120 dB (7 levels)
Communications		Acoustic modem, RS232 & Bluetooth wireless
Battery life (capacity)		Option: 504 Ah - up to 12 years typical Option: 180 Ah - up to 5 years typical (dependent on sensors and sampling interval)
Mechanical construction		Glass sphere, titanium parts (except duplex stainless steel guard) and polypropylene shell
Operating temperature		-5 to 35°C
Storage temperature	With batteries	0 to 30°C
	Without batteries	-5 to 35°C
Weight in air/water ¹	3,000 m with 180 Ah Battery	50 kg/-100 N
	6,000 m with 504 Ah Battery	107 kg/-250 N
Sensors and options		
Battery temperature		Standard
Temperature ($\pm 0.015^\circ\text{C}$)		Optional (integrated with pressure sensor)
High precision pressure sensor		Up to three sensors on single pressure port with diaphragm, including: Paroscientific DigiQuartz Sensor ($\pm 0.01\%$) Keller and/or Presens High Precision Strain Gauge ($\pm 0.01\%$)
Sound velocity sensor ± 0.02 m/s accuracy under calibration conditions		Optional
MEMS inclinometer ($\pm 0.5^\circ$)		Standard
High accuracy Jewell inclinometer ($\pm 0.05^\circ$)		Optional
Acoustic baseline ranging ²		Optional
Release mechanism (screw-off)		Optional
Battery disconnect fob		Standard
Stand		Not included (several options available)

¹ Actual weight dependent on sensor and other options.

² Not available for directional transducer beam shape.