

# Datasheet

## Subsea Monitoring, Analysis and Reporting Technology (SMART)



**Sonardyne has developed the Subsea Monitoring, Analysis and Reporting Technology (SMART) to cover a range of advanced subsea asset monitoring applications.**

SMART can be built and configured into a variety of housing configurations and material types to suit the application.

SMART provides low power electronics, long duration data logging, subsea data processing and acoustic telemetry in a single, easily deployed instrument.

SMART has the flexibility to interface with a wide range of internal and external sensors and other data sources, utilising standard or bespoke data analysis algorithms to provide the key data.

For structural monitoring applications SMART is outfitted as standard with a high performance Six Degrees of Freedom (6DOF) sensor package. This provides motion monitoring data which can be utilised for fatigue analysis and vibration monitoring including Vortex and Flow Induced Vibration (VIV and FIV).

By incorporating robust acoustic communications from Sonardyne's award winning 6G technology<sup>1</sup> SMART provides real-time monitoring functions. The on-board data processing converts time series data into a compact packet based on spectral and statistical analysis, enabling long duration monitoring campaigns.

In addition to the acoustic link SMART also has Ethernet and serial connections which can be used for data upload through cabled connections or for high speed data offload on retrieval.

Additional sensors including external strain gauges can be connected to SMART if required.

Standard topside software provides for data collection and system management. Data analysis functions can be added if required or data exported to third party applications.

### Typical applications

- Drilling and production riser fatigue monitoring
- Wellhead and conductor monitoring
- FIV and VIV monitoring
- SMART variants can be optimised to a wide range of applications

### Key features

- High quality 6DOF motion monitoring
- Configurable data logging with redundant storage
- On-board processing for real-time updates based on standard or bespoke algorithms
- Advanced acoustic telemetry using Sonardyne Wideband® protocols at up to 9,000 bps
- Ethernet connection for high-speed download; on deck or via BlueComm® optical modem to Remotely Operated Vehicle (ROV)
- Standard and bespoke topside software applications
- Highly configurable for all environmental conditions and operating water depths
- Expansion capability for additional internal sensors and analogue and digital interfaces to external sensors

<sup>1</sup> For full details of acoustic link parameters please refer to Sonardyne Compatt 6 (Type 8300) and compatible topside transceivers, which include Dunker 6 (Type 8309) and the High-Performance Transceiver (HPT) range (Type 8142) at [www.sonardyne.com](http://www.sonardyne.com).

# Specifications

## Subsea Monitoring, Analysis and Reporting Technology (SMART)

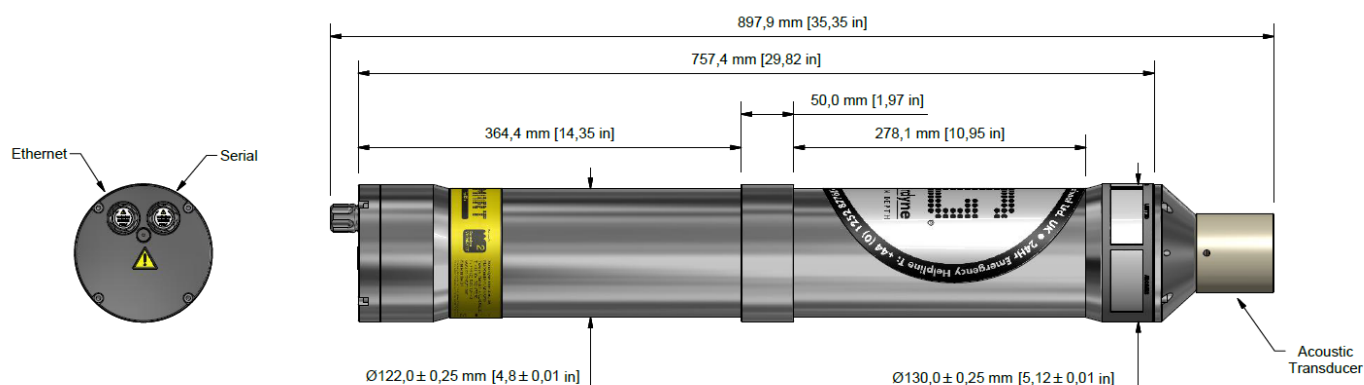

Instrument feature		Type 8316
Depth rating		3,000 m (up to 7,000 m on request)
Acoustic operating frequency		MF (20–34 kHz)
Acoustic data rate		100–9,000 bps
Standard battery specifications		100 Ah @ 15 V (high-capacity options available)
Power consumption	Listening	50 mW
	Logging	200 mW
Battery life (typical) - lithium		>500 days @ 25% logging duty, hourly reporting
Mechanical construction		Super duplex stainless steel
Weight in air/water		32/22 kg
Operating temperature		-5 to 30°C
Storage temperature		-25 to 70°C
SMART feature		Type 8316
6 Degrees of freedom high performance motion sensor		Standard
Triaxial acceleration measurement	Range	±30 ms <sup>-2</sup>
	RMS noise	6x10 <sup>-4</sup> ms <sup>-2</sup> /√Hz
	Instability	5x10 <sup>-4</sup> ms <sup>-2</sup>
Triaxial angular rate measurement	Range	±150 deg s <sup>-1</sup>
	RMS noise	0.002 deg s <sup>-1</sup> /√Hz
	Instability	2.2 deg/hr
Sensor axial misalignment		0.02°
Sampling rate		5 Hz, 10 Hz and 25 Hz
Anti-aliasing filter (standard)		-3 dB cut-off @ 4 Hz
Data storage		32 GB dual redundant, FAT32
Processing capability		Fully programmable including FFT spectral analysis, statistical functions and bespoke options
Logging and reporting scheme		Fully configurable
Connectivity		Acoustic link (for real-time reporting), Ethernet port (high speed data upload), serial port
Additional sensors		Optional internal and external sensors

The table above shows typical values for a SMART transponder configured for drilling riser fatigue monitoring. As a flexible instrumentation platform, alternative configurations are available including alternative motion sensors if higher sensitivity is required. SMART can be offered with a standard data processing algorithm for fatigue monitoring or can incorporate customer specific requirements on request.